

Yale PSB Steel Body Lever Hoists

- Compact design
- Lightweight
- Easy to free chain

The Yale PSB Steel-Body Lever Hoist has all the features of premium lever hoist but is priced for value. The innovative housing design makes the Yale PSB more compact and lightweight than ever before. Our state-of-the-art free wheel control allows you to quickly and easily take-up "slack" chain. A cushioned rubber grip is included on all models for ease of operation. The Yale PSB lever hoist is the best value in the marketplace today.

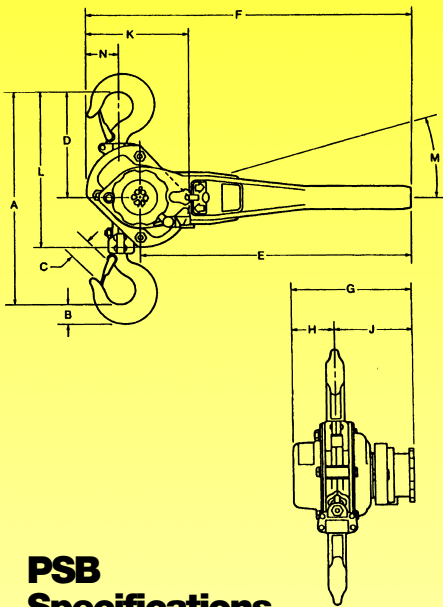

PSB Specifications

Model Number	Capacity		Lifts (ft.)	Hook Throat Opening (in.)	Minimum Headroom (in.)	Average Pull to Lift Rated Load (lbs.)	Minimum Increment in Lifting (in.)	Net Weight for 10 Ft. Lift (lbs.)
	(Lbs.)	(Ton)						
830-04100	1500	3/4	5-10-15-20	15/16	11 5/8	46	0.022	15
830-06100	3000	1 1/2	5-10-15-20	1 1/4	14 31/32	55	0.022	24
830-09100	6000	3	5-10-15-20	1 1/4	16 9/16	77	0.015	38
830-14100	12000	6	5-10-15-20	1 3/4	22 7/16	84	0.0075	74

PSB Dimensions

Model Number	Rated Load (lbs.)	A	B	C	D	E	F	G	H	J	L	M	N	No. of Load Chains
830-04100	1500	11 5/8	13/16	15/16	5 7/16	9 1/4	11 7/16	5 9/16	2 1/8	3 7/16	7 3/4	9	1 5/16	1
830-06100	3000	14 31/32	1 1/16	1 1/4	6 13/16	13 3/4	16 7/32	6 5/8	2 5/8	4	9 7/16	9	1 3/8	1
830-09100	6000	16 9/16	1 3/8	1 3/8	7 1/2	13 3/4	17 3/16	7 1/4	3 1/8	4 1/8	10 11/16	9	2 3/8	1
830-14100	12000	22 7/16	2 1/16	1 3/4	9 11/16	13 3/4	19 1/2	7 1/4	3 1/8	4 1/8	12 15/16	9	2 3/4	2

PSB Steel Body Lever Hoist

Capacities: 3/4 to 6 Ton

- **Rated Loads**-1,500 to 12,000 lbs., 3/4 to 6 ton.
- **Lifts**- 5-10-15-20 feet.
- **Portable and Durable**- All steel construction, lightweight and impact resistant.
- **Efficient Lifting and Load Positioning**- Double reduction gearing and short handle length reduce operator's effort.
- **Positive Load Control**- Enclosed screwtype load brake stays clean and dry for positive positioning.
- **Longer Chain Life**- Through hardened load chain provides high strength and resists wear.
- **Ease of Free Chaining**- Free wheel control provides fast take-up of slack chain (position the control lever to neutral). Lifetime warranty on free chain knob.
- **Safety Latches**- 360 degree swiveling hooks are equipped with latches for positive load engagement.

