

Yale NH hook type hand hoists

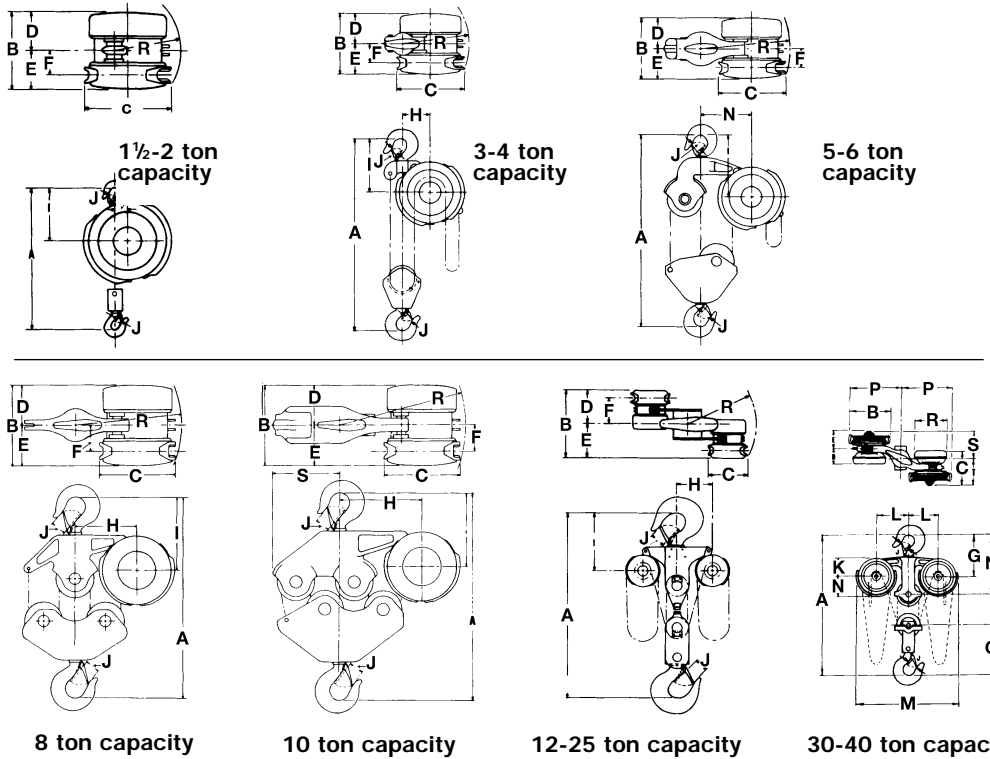

Product Code Number	Rated Capacity in Tons	Minimum Distance Between Hooks, in Inches	Chain Pull to Lift Full Load, in Pounds	Chain Overhauled to Lift Load One Foot, in Feet	Strands of Chain		*Length in Lineal Feet Standard Chain		Weight in Pounds	
					Load	Hand	Load	Hand	Net	Gross
826-03100	1/2	12 3/8	35	33	1	2	9	14'	44	46
826-05100	1	12 1/4	70	33	1	2	9	14'	46	48
826-06100	1 1/2	16 5/8	64	58	1	2	9'4"	14'	85	88
826-07100	2	16 5/8	83	58	1	2	10'4"	16'	85	88
826-09100	3	23 1/2	66	116	2	2	22'6"	18'	122	140
826-11100	4	24 1/2	86	116	2	2	22'6"	18'	130	144
826-13100	5	25 1/2	71	174	3	2	39'6"	22'	184	208
826-14100	6	25 1/2	88	174	3	2	39'6"	22'	184	208
826-16100	8	26 3/4	91	232	4	2	52'0"	22'	245	283
826-17100	10	30 3/4	94	290	5	2	65'0"	26'	310	355
826-18100	12	49 3/4	*88 (2)	*174	6	4	91'0"	26' (2)	660	720
826-19100	16	53 3/4	*91 (2)	*232	8	4	116'0"	26' (2)	825	900
826-20100	20	57 7/8	*95 (2)	*290	10	4	141'0"	26' (2)	1050	1130
826-22100	25	57 7/8	*103 (2)	*348	12	4	169'0"	26' (2)	1070	1160
826-23100	30	63	*107 (2)	*383	10	4	76'6"	20'6" (2)	2530	2700
826-24100	40	77	*122 (2)	*460	12	4	94'6"	21'6" (2)	3110	3450

*Standard lift is 8 feet.

NH DIMENSIONS IN INCHES

Cap. Tons	A	B	C	D	E	F	G	H	I	J	K	L	M	N	O	P	R	S	T
1/2	12 3/8	8 1/2	8 1/2	4 1/4	4 1/4	3	-	1 3/8	5 7/8	1	-	-	-	-	-	-	7	-	-
1	12 1/4	8 1/2	8 1/2	4 1/4	4 1/4	3	-	1 3/8	5 7/8	1	-	-	-	-	-	-	7	-	-
1 1/2	15 3/4	10	11	5	5	3 1/4	-	1 3/4	8 1/8	1 1/8	-	-	-	-	-	-	8 1/2	-	-
2	15 3/4	10	11	5	5	3 1/4	-	1 3/4	8 1/8	1 1/8	-	-	-	-	-	-	8 1/2	-	-
3	23 1/2	10	11	5	5	3 1/4	-	4 7/8	9 1/8	1 1 1/32	-	-	-	-	-	-	11 1/2	-	-
4	24 1/2	10	11	5	5	3 1/4	-	4 7/8	9 5/8	1 1 1/16	-	-	-	-	-	-	11 1/2	-	-
5	25 1/2	10	11	5	5	3 1/4	-	6 3/8	11 1/2	1 1 1/16	-	-	-	-	-	-	13 1/2	-	-
6	25 1/2	10	11	5	5	3 1/4	-	6 3/8	11 1/2	1 1 1/16	-	-	-	-	-	-	13 1/2	-	-
8	26 3/4	10	11	5	5	3 1/4	-	8 1/2	11	2 1/16	-	-	-	-	-	-	14	-	-
10	30 3/4	10	11	5	5	3 1/4	-	10 1/4	10 5/8	2 1/4	-	-	-	-	-	-	17	-	-
12	49 3/4	16	11	8	8	6 1/4	-	11 3/4	16	3	-	-	-	-	-	-	19 1/2	-	-
16	53 3/4	17 1/2	11	8 3/4	8 3/4	7	-	11 3/4	17 1/2	3 5/8	-	-	-	-	-	-	19 7/8	-	-
20	57 7/8	19 1/2	11	9 3/4	9 3/4	8	-	11 3/4	18	3 5/8	-	-	-	-	-	-	20 3/8	-	-
25	57 7/8	21 1/4	11	10 5/8	10 5/8	8 5/8	-	11 3/4	18	3 5/8	-	-	-	-	-	-	20 7/8	-	-
30	63	17 7/8	15	7 3/4	7 3/4	-	22	8 1/4	10 13/16	4 3/16	7 1/4	16 3/4	50 5/8	26	25 1/16	26 3/16	13 1/16	13	13
40	77	17 7/8	15	7 3/4	7 1/4	-	24 3/8	8 1/4	10 5/8	5 1/8	7 1/4	16 3/4	50 5/8	32 1/8	25 5/16	33 1/2	13 1/16	13	13